

THIS DRAWING IS UNPUBLISHED. RELEASED FOR PUBLICATION
 © COPYRIGHT BY TYCO ELECTRONICS CORPORATION. ALL RIGHTS RESERVED.

LOC	DIST	REVISIONS					
		P	LTR	DESCRIPTION	DATE	DWN	APVD
G	14		L1	REV PER ECR 06-001832	22APR06	JR	TM

AMP WIRE RANGE	Listed FILE E13288	LR7189 Certified
12-10 AWG SOLID OR STRANDED	12-10 AWG SOLID OR STRANDED	12-10 AWG SOLID OR STRANDED

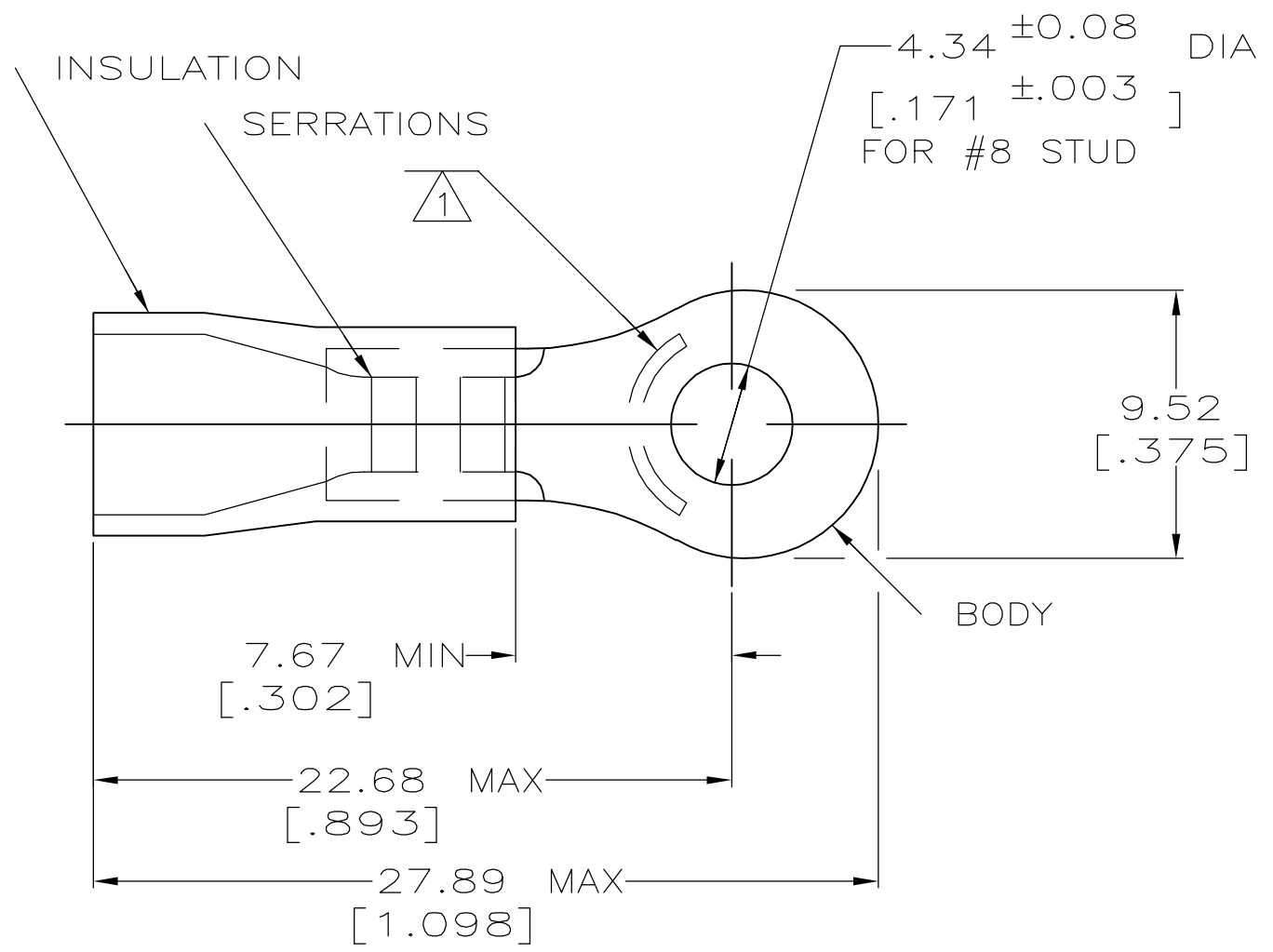

- ① STAMP AMP 12-10* APPROX AS SHOWN
- ② WIRE INSULATION DIA: .150-.250
- ③ TONGUE MATERIAL THK: 1.02^{±0.05} [.040^{±.002}]

QTY	PACKAGE TYPE	PART NO
25	LOOSE PIECE, BAG	8-34853-5
4	LOOSE PIECE, BLS	8-34853-4
100	LOOSE PIECE, BOX	8-34853-1
2500	ON TAPE, REEL	2-34853-1
-	LOOSE PIECE	34853

AMP INCORPORATED
CUSTOMER SERVICE SYSTEMS

FOR ADDITIONAL PRODUCT INFORMATION OR COPIES OF DRAWINGS AND TECHNICAL DOCUMENTS
 PRODUCT INFORMATION CENTER
 1-800-522-6752

FOR APPLICATION TOOLING INFORMATION
 TOOLING ASSISTANCE CENTER
 1-800-722-1111

FOR ORDER ENTRY
 1-800-526-5142

MAX RECOMMENDED OPERATING TEMPERATURE:
 105°C [221°F]

VOLTAGE RATING:
 N/A

CIRCULAR MIL AREA:
 2.62-6.64mm² [5,180-13,100]
 SOLID OR STRANDED

THIS DRAWING IS A CONTROLLED DOCUMENT.

DIMENSIONS: INCHES

TOLERANCES UNLESS OTHERWISE SPECIFIED:

0 PLC	± -
1 PLC	± -
2 PLC	± 0.20 [.008]
3 PLC	± -
4 PLC	± -
ANGLES	± -

MATERIAL: COPPER ASTM B-152
 PVC: COLOR - YELLOW

FINISH: TIN PLATE PER ASTM B545

DWN DK SCHRUM 08/06/92
 CHK RE HERSEY 11/10/92
 APVD M BARNABA 11/10/92

tyco Tyco Electronics Corporation
Electronics Harrisburg, Pa 17105-3608

NAME: TERMINAL, RING TONGUE, PLASTI-GRIP

PRODUCT SPEC: UL 486A

APPLICATION SPEC: 114-2161

WEIGHT: -

SIZE: A3 CAGE CODE: 00779 DRAWING NO: C-34853 RESTRICTED TO: -

CUSTOMER DRAWING SCALE: 4:1 SHEET: 1 OF 1 REV: L1